

Angle Plate

I wanted a small angle plate. On the web I found several angle plates on offer, but they were a bit expensive. I had a piece of 60mm angle iron in my pile of scrap and decided to try to make a pair of angle plates since the piece was long enough. I wanted webbed angle plates and decided to silver solder some pieces of steel to the ends of each angle plate.



Materials

I used a 160mm long piece of 60mm angle iron, and two pieces of 8 x 15mm steel a little over 150mm long and a piece of 4mm diameter steel rod. The angle iron was clamped to the milling table and a light cut taken on the top to get it parallel to the bottom.

Support webs

The webs were made from a piece of 8x15mm steel. I first cut each piece in two, drilled two 4.2mm holes through both. The holes in one piece was tapped M5, in the other the holes were opened up to 5mm. I screwed two webs together and milled all sides. I used a protractor and clamped them to the milling table at 45° with brass shims under the work. I could then mill both ends to 45° by using the longitudinal and cross feed screws.

I milled a small part of the inside of the angle iron where the webs will make contact. This will give a clean surface when silver soldering.

To make sure that the support webs stay in place while silver soldering I decided to drill 2.5mm holes through the corners of the angle iron and into the webs. The parts of the holes in the webs were tapped M3, and the holes in the angle irons opened to 3mm and countersunk. I used a small C clamp to clamp the webs in place while drilling.



I chucked a piece of 4mm diameter mild steel and turned it down to 3mm for a length of 10mm. Most of that was threaded M3 with a die held in a tailstock die holder. The other end was turned to fit the countersunk hole in the angle iron. The heads were made a little longer than necessary; the protruding parts will be milled away afterwards.

I applied soldering flux to the angle iron and web pieces and used the home made screws to hold the parts together before soldering (right picture).

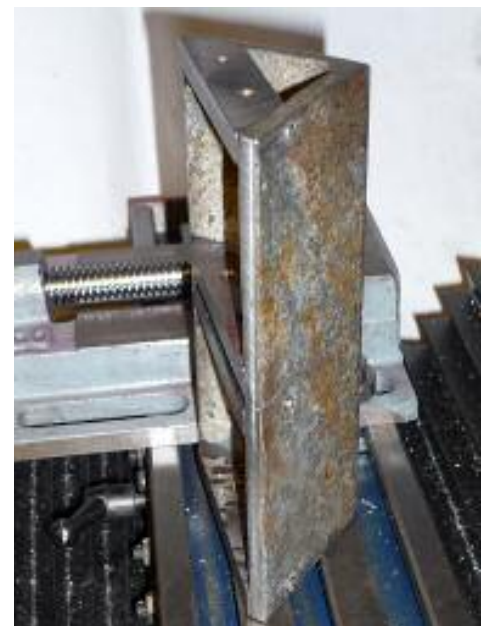

Drilling and milling the soldered parts

After soldering I mounted the angle iron in a vice. I used two small machinists jacks to assist in the clamping (they are barely visible in the picture to the right). I drilled a couple of 6mm holes so the angle plate could be clamped to a square cast iron box I have had for many years. This way I could mill the angle plates and get the sides square.



The square cast iron box was clamped to the milling table and a dial indicator used to set it parallel to the longitudinal movement of the milling table.

Here is a picture of the angle plate clamped to the cast iron box. The top face has been milled and one of the sides is being milled. The long angle iron was then cut in two with a hacksaw to give a pair of angle plates. The bottom picture shows how I milled the hack sawed ends.



The 6mm holes were milled to create short slots using a 6mm slot drill. The angle plates were heated and dipped in oil to give some rust protection.

Narrow Angle Plate

For some jobs an angle plate that allows clamping on both sides are needed. I happened to have an offcut from a piece of 30mm thick steel in my scrap bin. It was L shaped and cut with an oxy-acetylene cutter. The heat from the cutting made the cut surfaces hard so I used a carbide tipped cutter to mill the work. The arms were almost 70 mm long and around 13-14mm thick. This makes the angle plate stiff even if there is no support webs.

The first job was to mill one of the outer surfaces so the work could be clamped to a square cast iron box. The box has T slots on the top and slots for clamping bolts on four sides, you can see it sitting at the end of the milling table in the background on the picture to the right.

The work is clamped between my largest clamps and the surface facing upwards has been milled and two 6mm diameter holes drilled and deburred. The work was then turned and two similar holes drilled in the other arm.

The square cast iron box was clamped to the milling table and the work clamped to the box using the M6 Allen screws. A square was used to keep the clamped arm square with the table surface before tightening the screws. I used a couple of other clamps to prevent the work from moving while milling the top surface (right picture).



Here the angle plate is clamped to the milling table so the ends can be milled.

After milling the ends one of the 6mm Allen screws were removed and the hole opened up to 8mm about half-way through with a twist drill. I then used an end-mill to square the bottom of the hole. The depth of the 8mm part of the hole was deep enough so the head of an M5 Allen screw was well beneath the top surface. I then made a couple of T-nuts to suit the Mini-Mill table slots and tapped them M5. The bottom right picture shows the work clamped to the milling table after milling the last "inner" surface of the angle plate. The square box and three other clamps are used to prevent the work from moving while milling the hard surface.

The two holes in each arm were drilled through with a 8mm drill and the work was then clamped to the square box again and a slot drill used to mill a 8mm wide slot between the two holes. The bottom left picture shows the last slot after chamfering.



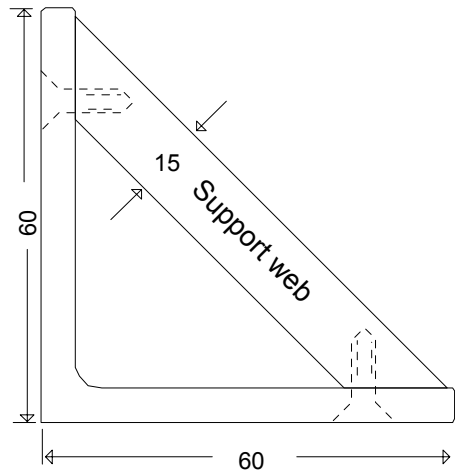

Side view

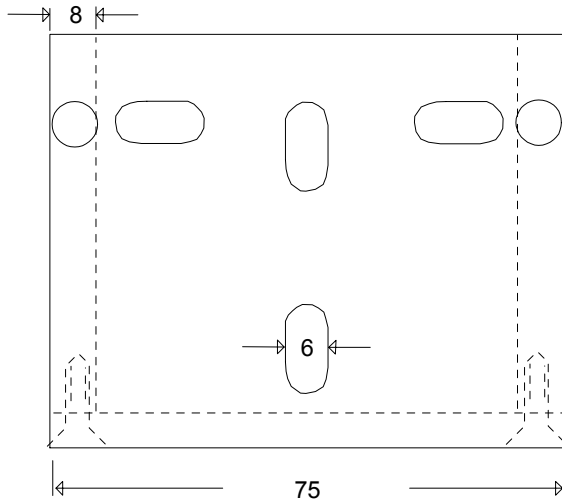

Front view

Date:	2009	Tegner	TH	Material:	Steel	⊙ □	1 : 1
Angle Plates							